

MASS SPECTROMETRY WORKSTATION

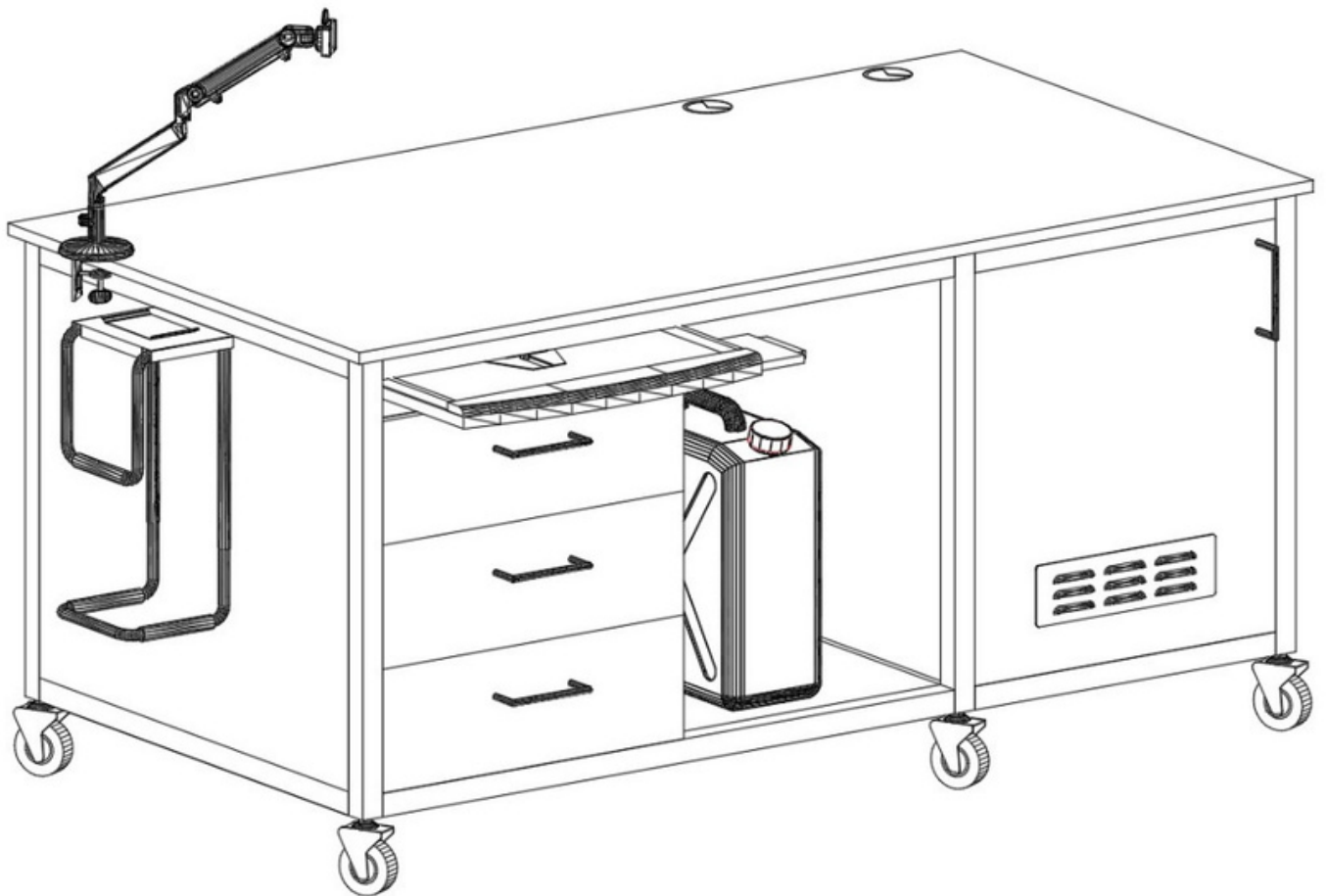

MASS SPECTROMETRY workstation

1900 x 1000 x 900mm workstation
Consisting of:

- 16mm thick Chemical resistant Phenolic resin worktop
- Drawer cabinet with 3 drawers
- Undermount key board tray
- Heavy duty frame work with 6nos castors (weight capacity 480Kgs)
- Storage cabinet for pump unit with noise reduction paneling, anti vibration pad mounted bottom, pullout shelf fixed on heavy duty drawer slides and louver grill for ventilation
- Storage space for liquid waste collection with 2grometts on worktop to run the drain tube.

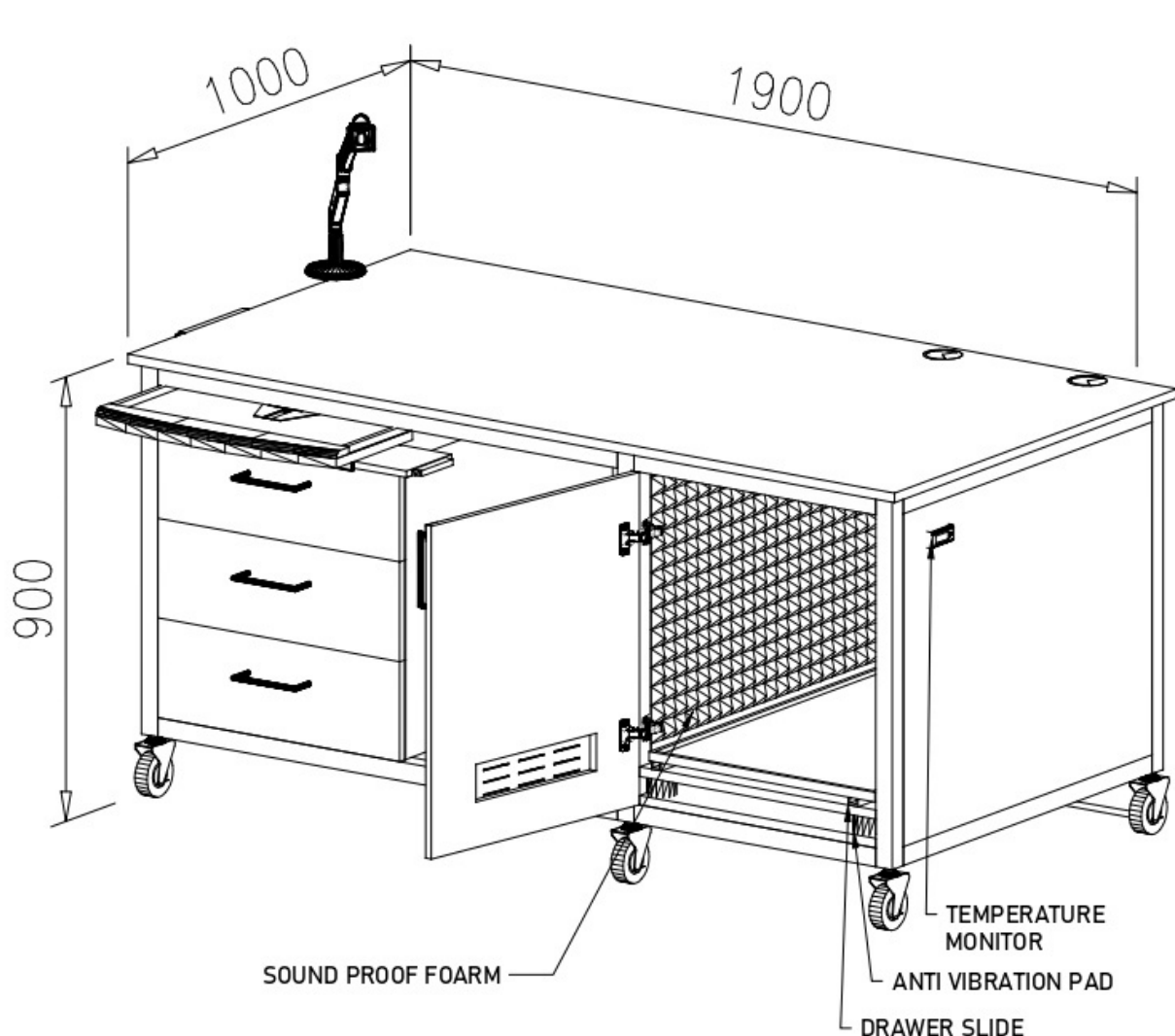
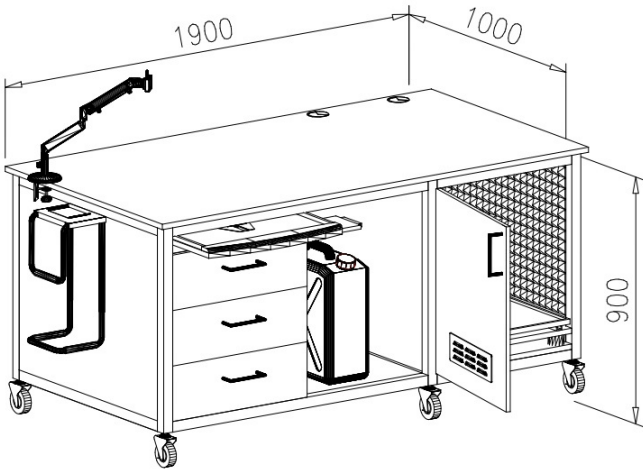

SECTIONAL DETAILS OF STORAGE CABINET

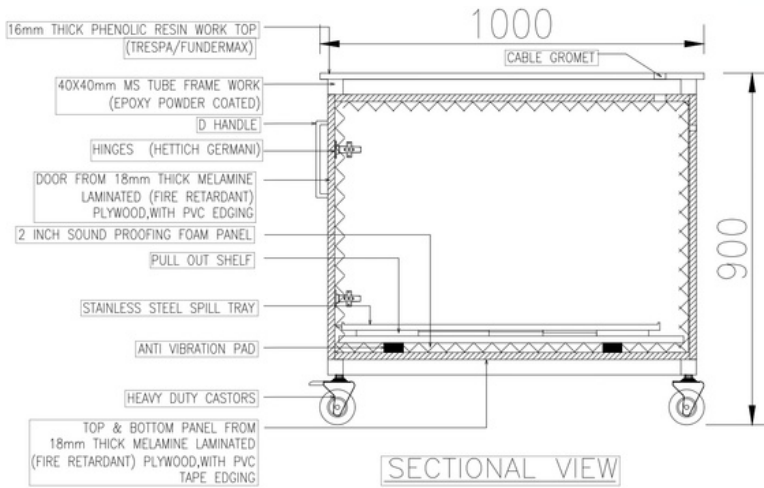

DATA SHEET FOR CARCASS MATERIAL

KINGSA FIRE RETARDANT PLYWOOD – 18mm

Moisture Content (%) :	10-14
Density (Kg/M3) :	800
Glue Shear Strength (Kg/sq inch) :	140
Water Resistance Test (Kg/sq inch) :	120
Mycological Test (Kg/sq inch) :	115
Bending Strength (Kg/sq cm) :	500
MOE parallel to face grain (N/mm2) :	6000
MOE perpendicular to face grain (N/mm2) :	3300
MOR parallel to face grain (N/mm2) :	45
MOR perpendicular to face grain (N/mm2) :	25
Flammability (Minutes) :	45
Flame penetration (Minutes) :	4 times of thickness of plywood
Rate of Burning (Minutes) :	40
Retention of Fire Retardant Chemicals (Kg/M3) :	60-70
Screw Holding Strength (Kg) :	225
Nail Holding Strength (Kg) :	75
Adhesion of Plies (Knife test) :	Excellent



MEDIUM DUTY CASTORS

3" Threaded Plastic Dual Brake TPU Caster - Medium Duty
130kg Dynamic load, Threaded Brake, Chrome Coated,



SS D- HANDLE

D- BAR Pull handle for Cabinets. Made of Stainless steel
10mm Dia x 128mm long



VENTILLATION GRILL

Made of GI powder coated, ventilation grill have been designed for use
with ventilation fans within rack server cabinets

Fast assembly concealed hinge with integrated Silent System





- ▶ Sensys 8657i, 0 protrusion hinge
- ▶ 165° opening angle



- ▶ Concealed clip on hinge with integrated Silent System
- ▶ Quality classification under EN 15570, Level 3
- ▶ For door thickness of 15 – 32 mm
- ▶ Cup diameter 35 mm
- ▶ Cup depth 11.6 mm
- ▶ Integrated overlay adjustment + 2 mm / - 2 mm
- ▶ Integrated depth adjustment + 3 mm / - 2 mm
- ▶ Height adjustment at mounting plate
- ▶ Opening angle can be reduced by means of optional accessory
- ▶ 0 protrusion hinge
- ▶ Hinge arm material: nickel plated steel
- ▶ Hinge cup material: nickel plated steel

Sensys 8657i, 165° opening angle

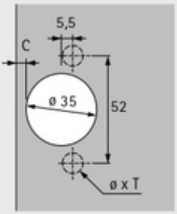
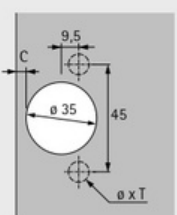
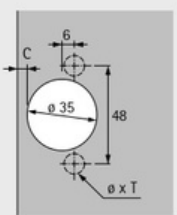
Cup installation	Drilling pattern	Fixing hole ø x T mm	Full overlay	Half overlay	PU
					
			Basis B 12.5 mm	Basis B 3 mm	
Screw on version TH 52		-	9 099 540	9 099 550	50 ea.
Press in version TH 53		ø 10 x 11	9 099 541	9 099 551	50 ea.
Flash fast assembly TH 54		ø 10 x 11	9 099 542	9 099 552	50 ea.
Fix fast assembly THS 55		ø 10 x 6	9 099 543	9 099 553	50 ea.
With prem. Euro screws TH 56		ø 5 x 11	9 099 544	9 099 554	50 ea.
Screw on version TB 52		-	9 099 560	9 099 570	50 ea.
Press in version TB 53		ø 8 x 11	9 099 561	9 099 571	50 ea.
Flash fast assembly TB 54		ø 8 x 11	9 099 562	9 099 572	50 ea.
Fix fast assembly TB 55		ø 8 x 6	9 099 563	9 099 573	50 ea.
With prem. Euro screws TH 56		ø 5 x 11	9 099 564	9 099 574	50 ea.
Screw on version TS 52		-	9 099 580	9 099 590	50 ea.
Press in version TS 53		ø 10 x 11	9 099 581	9 099 591	50 ea.
Flash fast assembly TS 54		ø 10 x 11	9 099 582	9 099 592	50 ea.
Fix fast assembly THS 55		ø 10 x 6	9 099 543	9 099 553	50 ea.
With prem. Euro screws TH 56		ø 5 x 11	9 099 584	9 099 594	50 ea.

WORKTOP - TRESPA Toplab plus



SCIENTIFIC SURFACE SOLUTIONS

MORE THAN 55 YEARS OF RESEARCH, TECHNOLOGY AND INNOVATION









Trespa International is a leading innovator in the field of architectural materials. Thanks to more than 55 years of global experience and product innovation, Trespa is recognised internationally as a premier developer of high-quality panels for scientific surface solutions.

3

TRESPA® TOPLAB®

SCIENTIFIC SURFACE SOLUTIONS

THE IDEAL CHOICE FOR SAFE AND DURABLE SCIENTIFIC ENVIRONMENTS

							
24 HOURS CHEMICAL RESISTANT	DOES NOT SUPPORT BACTERIAL GROWTH	SCRATCH & WEAR RESISTANT	EASY TO CLEAN	QUICK INSTALLATION	EXCELLENT MACHINABILITY	SUITABLE FOR CONTACT WITH FOOD	IMPACT RESISTANT

Today's laboratory and functional environments demand compliance with rigorous codes and standards. Therefore, selecting the right material is of crucial importance. Whatever product from the Trespa® TopLab® line you choose, this high-pressure compact laminate, fabricated with natural fibres and thermosetting resins, will extend the lifetime of your laboratory worktops, cabinets and shelving noticeably.

10-YEAR PRODUCT WARRANTY
The unique properties of Trespa® TopLab® panels make them highly durable. That is why Trespa offers a 10-year conditional warranty on its product lines. To learn more about our warranty, please visit Trespa.info.

TESTING, CERTIFICATION AND BRANCH ASSOCIATIONS
Trespa® products for scientific surface solutions are tested and certified according to international standards in relation to chemical resistance, low emission, food contact and other properties. TopLab^{OFFICE}, TopLab^{HYGIENE} and TopLab^{INDUSTRIAL} are certified under the

GREENGUARD Gold Certification program. Trespa International B.V. is a member of SEFA (Scientific Equipment and Furniture Association), EGNATON (European Association for Sustainable Laboratory Technologies) and VIP3000 (Association for Cleanrooms and Pharmaceutical Construction).



USING RENEWABLE RESOURCES
Trespa® TopLab^{OFFICE} and ^{INDUSTRIAL} are available within the Programme for the Endorsement of Forest Certification (PEFC) or Forestry Stewardship Council® (FSC®) certification upon request for restricted quantities and jurisdictions. The use of FSC® and PEFC® certified Trespa® panels may also contribute to points associated with green building certification systems like LEED, BREEAM and DGNB. These certifications are one of the initiatives resulting from Trespa's Sustainability Policy, by which Trespa shows its commitment to the use of raw materials from sustainable origin and to forest preservation.



TRESPA TOPLAB^{PLUS} - CHEMICAL RESISTANCE

(24 HOURS EXPOSURE)

Test procedure

The test was conducted by applying 5 drops of each reagent on the surface, covered with a watch glass (except those marked**). Chemicals marked ** were tested with a saturated cotton ball covered by a bottle. All chemicals were tested at room temperature for a period of 24 hours, rinsed off with water and evaluated.

Test results

No effect: No detectable stain, loss of gloss or change in work surface material.

Excellent: Slight stain or loss of gloss, but no change to the function, smoothness or life of the work surface material.

Good: A clearly discernible stain or loss of gloss, but no change to the function, smoothness or life of the work surface material.

Fair: Unacceptable staining or discernible deterioration or etching of the work surface material.

Failure: Severe stain or moderate deterioration, pitting cratering or etching of work surface material.

		No effect	Excellent	Good	Fair	Failure
Acids						
Acetic Acid	99%	■				
Acid Dichromate	5%	■				
Chromic Acid	60%	■				
Formic Acid	90%	■				
Hydrochloric Acid	10%	■				
Hydrochloric Acid	37%	■				
Hydrofluoric Acid	48%					■
Nitric Acid	20%	■				
Nitric Acid	30%		■			
Nitric Acid	65%			■		
Nitric Acid	70%			■		
Nitric Acid 65% : Hydrochloric Acid 37%	(1:3)	■				
Perchloric Acid	60%	■				
Phosphoric Acid	85%	■				
Sulphuric Acid	25%	■				
Sulphuric Acid	33%	■				
Sulphuric Acid	77%	■				
Sulphuric Acid	85%	■				
Sulphuric Acid	98%		■			
Sulfuric Acid 77% : Nitric Acid 70%	(1:1)			■		
Sulfuric Acid 85% : Nitric Acid 70%	(1:1)			■		
Bases						
Ammonium Hydroxide	28%	■				
Sodium Hydroxide	10%	■				
Sodium Hydroxide	20%	■				
Sodium Hydroxide	40%	■				
Sodium Hydroxide Flake		■				
Salts						
Copper Sulphate	10%	■				
Ferric(III)chloride	10%	■				
Potassium Iodite	10%	■				
Potassium Permanganate	10%	■				
Saturated Zinc Chloride		■				
Silver Nitrate	1%	■				
Sodium Chloride	10%	■				
Sodium Hypochlorite	13%	■				
Halogens						
Iodine (Crystals)			■			
Iodine Solution (0.1 N)			■			
Tincture of Iodine			■			
Organic Chemicals						
Cresol		■				
Dimethylformamide		■				
Formaldehyde	37%	■				
Furfural			■			

WORKTOP (OPTIONAL) - TRESPA Toplab plus

		No effect	Excellent	Good	Fair	Failure
Gasoline		■				
Hydrogen Peroxide	3%	■				
Phenol	90%	■				
Sodium Sulfide Saturated		■				
Solvents**						
Acetic Anhydride		■				
Acetone		■				
Acetonitrile		■				
Amyl Acetate		■				
Benzene		■				
Butyl Alcohol		■				
Carbon Tetrachloride		■				
Chloroform		■				
Dichlor Acetic Acid		■				
Dichloromethane		■				
Dioxane		■				
Diethyl Ether		■				
Ethylacetate		■				
Ethylalcohol		■				
Ethylene Glycol		■				
Methylalcohol		■				
Methylene Chloride		■				
Methylethylketone		■				
Methylisobutylketone		■				
Mono Chlorobenzene		■				
Naphelene		■				
n-Butyl Acetate		■				
Tetrahydrofurane		■				
n-Hexane		■				
Toluene		■				
Trichloroethylene		■				
Xylene		■				
Biological Stains						
Acridine Orange	1%	■				
Alizarin Complexone Dihydrate	1%	■				
Aniline Blue, water soluble	1%	■				
Basic Fuchsin	1%	■				
Carbol Fuchsin	1%	■				
Carmine	1%	■				
Congo Red	1%	■				
Gentian Violet (dye)	1%	■				
Eosin B	1%	■				
Giemsa Stain	1%	■				
Malachite Green Oxalate	1%	■				
Methyl Violet 2B	1%	■				
Methylene Blue	1%	■				
Safranin O	1%	■				
Sudan III	1%	■				
Wright Stain	1%	■				
Most conventional cleaning agents		■				



The chemicals mentioned in the above table include the 49 chemicals/concentrations listed by SEFA (Scientific Equipment and Furniture Association) as well as the main reagents from the PSI (Professional Service Industries/Pittsburgh Laboratory Division).

All information is based on our current state of knowledge. It is intended as information concerning our products and their application possibilities, and is therefore not intended as any form of guarantee with regard to any specific product characteristic. Test results differ per colour.

Although the tests have been conducted according to the standard, it is recommended that users conduct their own tests: convince yourself that Trespa TopLab^{PLUS} is the only true multifunctional worktop!

Please check www.trespa.info for the latest version of the material properties and delivery programme.

OPTIONAL ACCESSORIES

Temperature Control with sensor and alarm



- Alarm when temperature exceeds temperature limit or when sensor error, so it is no need to pay attention to temperature changes at all times.
- Widely used in industrial machines and equipments, tube heaters, fans, oil filled heaters, convection heaters, electric radiators or any other heating and cooling appliances.
- 220VAC±10%, 50/60Hz. Power consumption: less than 3W.
- -50~99 Degree C. Resolution: 0.1 °C; 3. Accuracy: ±1 °C (-50~70°C).

Noise reduction Foam

Product Advantages

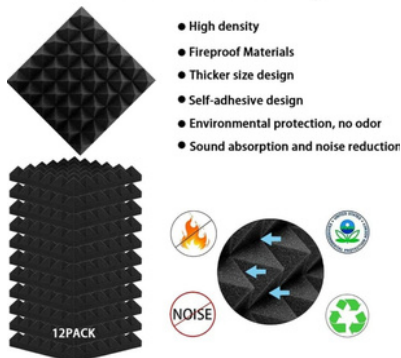

- High density
- Fireproof Materials
- Thicker size design
- Self-adhesive design
- Environmental protection, no odor
- Sound absorption and noise reduction

- 2 inch pyramid 3D acoustic design provides moderate sound control on walls or ceilings. High-density materials its tiny particles design which are effective to absorb noise and eliminate echoes.
- Achieve the optimum sound absorption and reflection with our 2-inch thick pyramid-shaped soundproof wall panels, achieving maximum surface area for the utmost sound control. Easy to shape and cut to size, customizing the shape you like and won't affect performance.

Quiet Cabinet Fan, Black



- An ultra quiet fan system designed for cooling cabinets that requires minimal noise.
- Features a multi speed controller to set the fans speed to optimal noise and airflow levels.
- Contains a CNC machined aluminum frame with a modern brushed black finish.
- Powered by wall outlet or USB port, included Turbo Adapter increases performance by 25 percent.
- Dimensions: 8.5 x 4.4 x 1.3 in. | Total Airflow: 52 CFM | Total Noise: 18 dBa | Bearings: Dual Ball

OPTIONAL ACCESSORIES

Adjustable Under-Desk CPU Holder with 360 Degree Swivel



Mounts CPU to Underside of Work Desk for Easy Access and Keep It Off the Floor 360 Degree Swivel for Easy Access to Cables and Ports at Back of CPU Sturdy Steel Construction with 50% Recycled Content

Colours: Black or White

Single Arm Monitor Desk Mount Stand



High Quality Monitor Desk Mount Stand Easy to Use Fingertip-Adjustable Pneumatic Gas Cylinder Integrated Monitor Arm

Colours: Black, Grey or White

Adjustable Under-Desk CPU Holder with 360 Degree Swivel



- Keyboard platform for under-desk fixing with ball bearing runners
- The auxiliary tray for the mouse
- Made in grey colour plastic
- Storage compartment with lid for small office utensils, pens or pencils

Colours: Grey

CONTACT US

BON FURNITURE INDUSTRIES LLC

P.O. Box 66902, Emirates Industrial City, SHARJAH – UNITED ARAB EMIRATES

Tel: +971 6 5569188, Mobile: +971 50 6703704, +971 52 6475053, Email: sales@bonlabin.com

KINGDOM OF SAUDIARABIA

**Integrated Modern Scientific Supplies LLC
PO Box- 285639, Riyadh-11323,
Kingdom of Saudi Arabia
Tel: +966 11 293 1199, Fax: +966 11 293 2299
E Mail: sultan@gulfbioanalytical.com**

INDIA

**Chrom Assure Labs Private Limited
Fl. No H 203, SaiMistique, S No. 11
Near Sinhagad Institute, AmbegaonBk,
Pune 411046, INDIA
Tel: +91 8080144312, +91 9921810805
E Mail: suvrat@chromassurelabs.com**

KUWAIT

**Ideal Perfect Company
Mubarak Commercial Complex, 2nd Floor,
Office # 7, Jleeb Al Shuwaikh. Kuwait
Tel: +965 67775807, +965 99703872
E Mail: ipcokuwait@gmail.com**

QATAR

**Meica Trading Contracting & Services W.L.L
P.O. Box no.32522, Regus Business Center,
Al Mataar Al Qadeem, State of QATAR
Mobile: +974 33277678 Tel: +974 44231189
Email: shankar.d@meicaqatar.com**

SULTANATE OF OMAN

**Modern Star Duqm Projects TradAsstd
PO Box-175, PC-319, W. Sohar
Sultanate of Oman
Tel: +968 96329633, +968 96696005
E Mail: msdpsohar@gmail.com**

KENYA

**Nelliwa Builders Ltd
P.o. Box. 68121, Code: 00200.
Nairobi, Kenya
Tel: + 254727329627
Email: info@morayme.com**