

# BALANCE BENCH

## ANTI VIBRATION TABLE



A sensitive and precision measurement is influenced by insensible ambient vibration of the ground and the building.

The low resonance frequency design of the anti-vibration table can reduce from low frequency vibration.

BONlab Anti vibration table structure is made of 100 x 50 x 2 mm thick MS tube epoxy powder coated with leveling feet to accommodate uneven surfaces and full size scratch resistant Granite slab mounted on shock absorbing rubber mount.

The working area of Granite top surface measures 900 x 750mm as standard which allows sufficient space for large balances.

Overall size: 900 x 750 x 900mm height

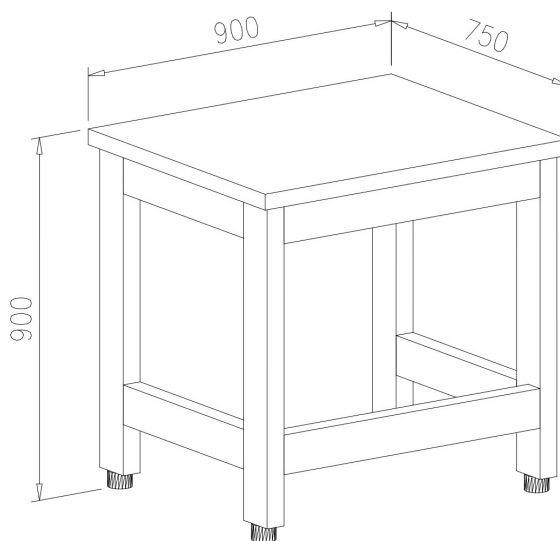

**Key features of BONlab Anti Vibration tables are:**

- Large working surface
- Scratch resistant Granite slab
- Heavy duty Metal frame works
- Adjustable leveling feet
- Robust construction for durability
- Epoxy powder coated finish
- Also designed and manufactured in Customized sizes.