

# EXPULSER

## FUME HOOD



FUME CONTAINMENT SOLUTIONS

EXTRACTION SYSTEMS

ACCESSORIES



**BONLAB**  
LABORATORY FURNITURE

## TABLE OF CONTENTS

<b>03</b> Fume Hood / Cupboards	<b>10</b> Optional - ATEX rated Accessories
<b>04</b> Purpose of Fume Cupboard	<b>11</b> Air flow Monitor panel
<b>05</b> Function of Fume Cupboard	<b>11</b> Fire Suppression systems
<b>07</b> Types - Bench Mounted	<b>12</b> Auxiliary Air supply unit
<b>08</b> Types - Walk-in Fume cupboard	<b>13</b> Suction / Extraction arms
<b>09</b> VAV Fume Cupboard	<b>14</b> Pictures
<b>10</b> Optional - Bypass systems	<b>17</b> Our Partners



For more information  
Download PDF  
page for  
FUMEHOOD



## FUME HOOD (FUME CUPBOARD)

A Laboratory fume hood (Fume cupboard) is a type of local exhaust ventilation system inside the laboratory. It is a typical enclosed cabinet except front face. The front opening will be equipped with a moving sash made out of toughened / safety glass. Air is drawn in to the hood under, through the opened sash and is exhausted through openings in the rear & top of the cabinet to a remote point such as an exhaust stack on the roof of the building.

**Chemical fume hoods, when used properly are one of the most reliable engineering controls in the Laboratory. They protect the users by:**

Containing vapors, dusts, gases, fumes etc generated within the hood, and removing them as airflows in to the hood and then out via the laboratory exhaust systems.

Contributing to laboratory ventilation as air flows through the hood.

Shielding the user with a clear sliding window called sash, that controls aerosols and prevent injury from splashes, fires or minor explosions that may occur inside the cupboard.



## PURPOSE of Fume cupboard in Laboratory

Laboratory fume hoods are one of the most important equipment's used to protect laboratory personnel from exposure to toxic gases, hazardous chemicals fumes and harmful vapors generated during experiments inside the fume hoods.



## FUNCTION

A laboratory fume hood is equipped with a baffle designed to control air flow patterns within the enclosure and manage an even distribution of air at the opening. When connected to properly designed exhaust system, the fume hood will carry the undesirable effluents -generated within the enclosure during a laboratory procedure- away from laboratory personnel. When used properly, they can provide an effective backup safety device for the containment and exhaust of toxic, offensive or flammable materials.

## DESIGNING

We create design, based on your need.



## MANUFACTURING

Manufacturing, complying to International standards



## INSTALLATION

Responsible installations & after sales services

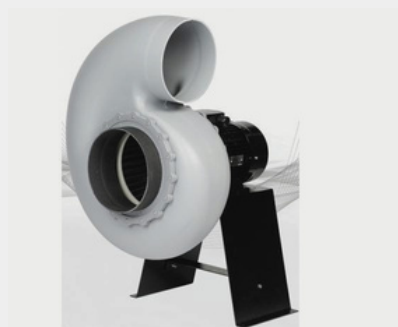

## FUNCTION

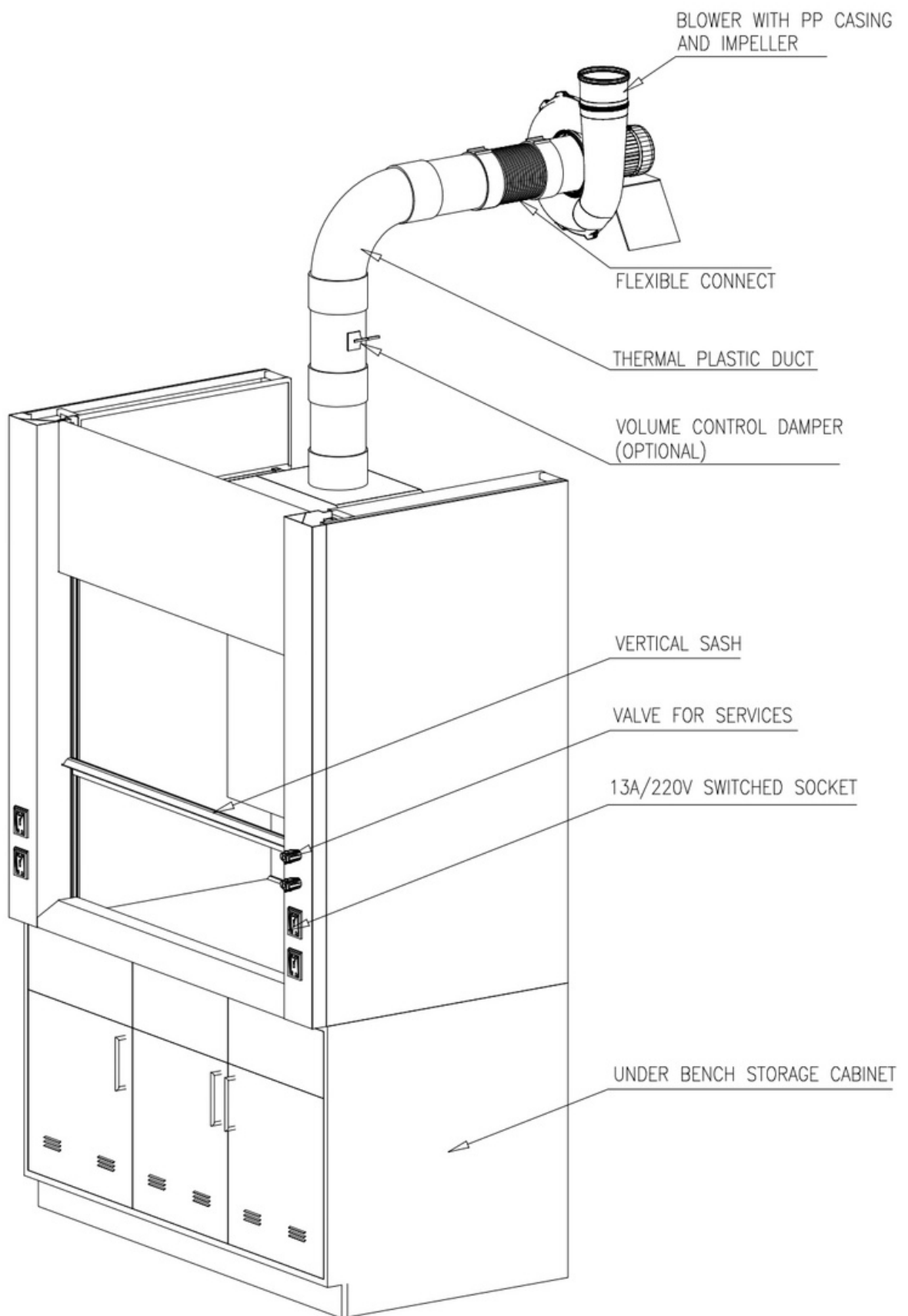

## TYPES OF FUME CUPBOARD

### BENCH MOUNTED FUME CUPBOARD

Majority fume hood types are bench mounted. Mainly, there are two parts for Fume Hood.

a) Fume Hood Upper Unit, b) Fume hood Base cum storage  
(In case of Walk-in type Fume Hood, there is Upper Unit only)

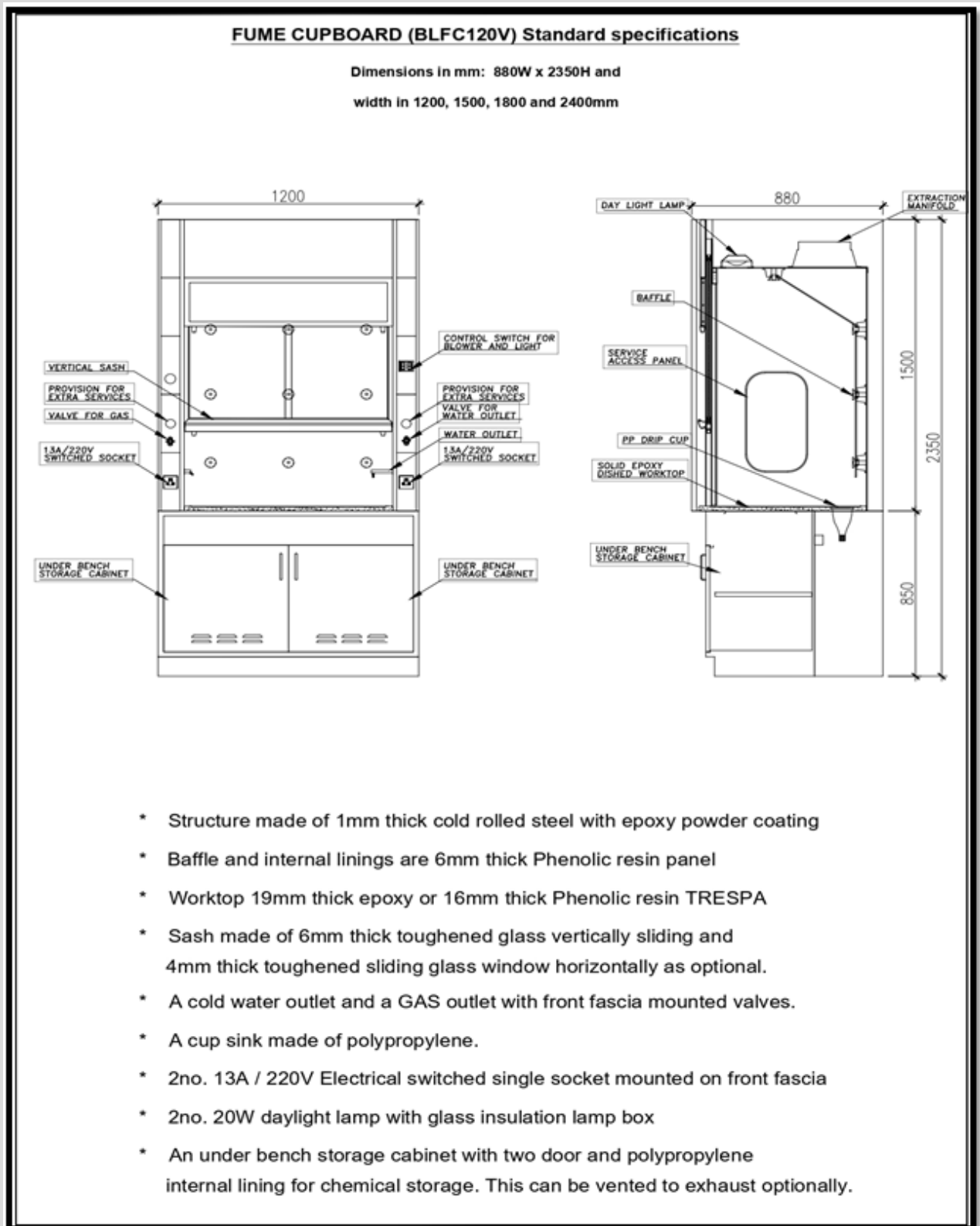

## TYPES OF FUME CUPBOARD

### WALK-IN TYPE FUME CUPBOARD

Walk-in fume hood are basically a bench hood that reach the floor, do allow users to walk in and out to set up equipment before and after work begins.

Walking fume hood is also known as a Floor Mounted Fume hood.

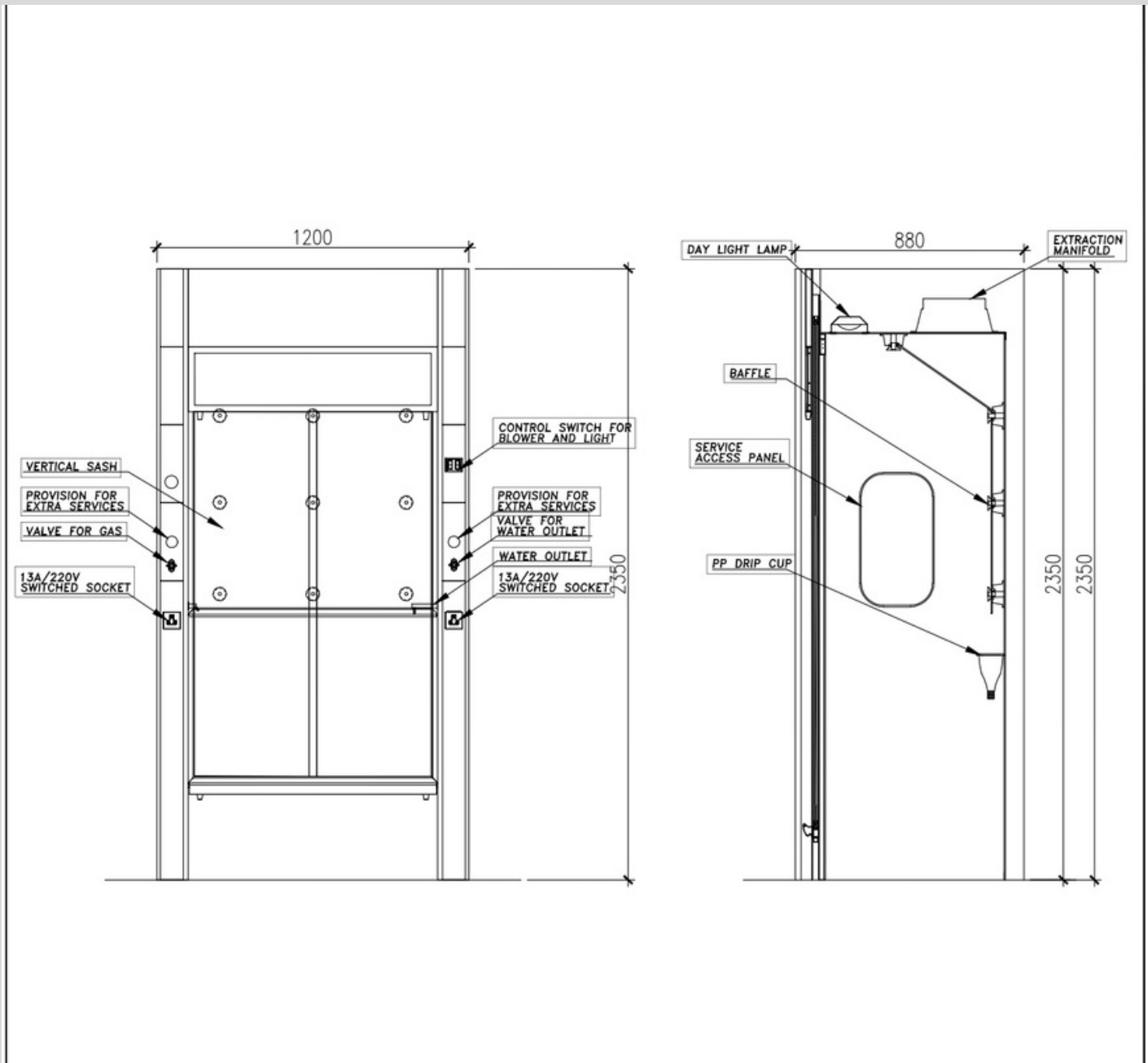

Walk-in fume cupboard is appropriate for placing large floor standing equipments.

The standard sash arrangement for walkin fume hood will be double sash opening. However, this can be customized for special applications



## TYPES OF FUME CUPBOARD

### VARIABLE AIR VOLUME FUME CUPBOARD

Variable air volume (VAV) fume hood design is for the regulation of air flow, rather than being a constant air flow system, the VAV fume hood allows for variation thereby reducing unwanted airflow and overall cost of operation.

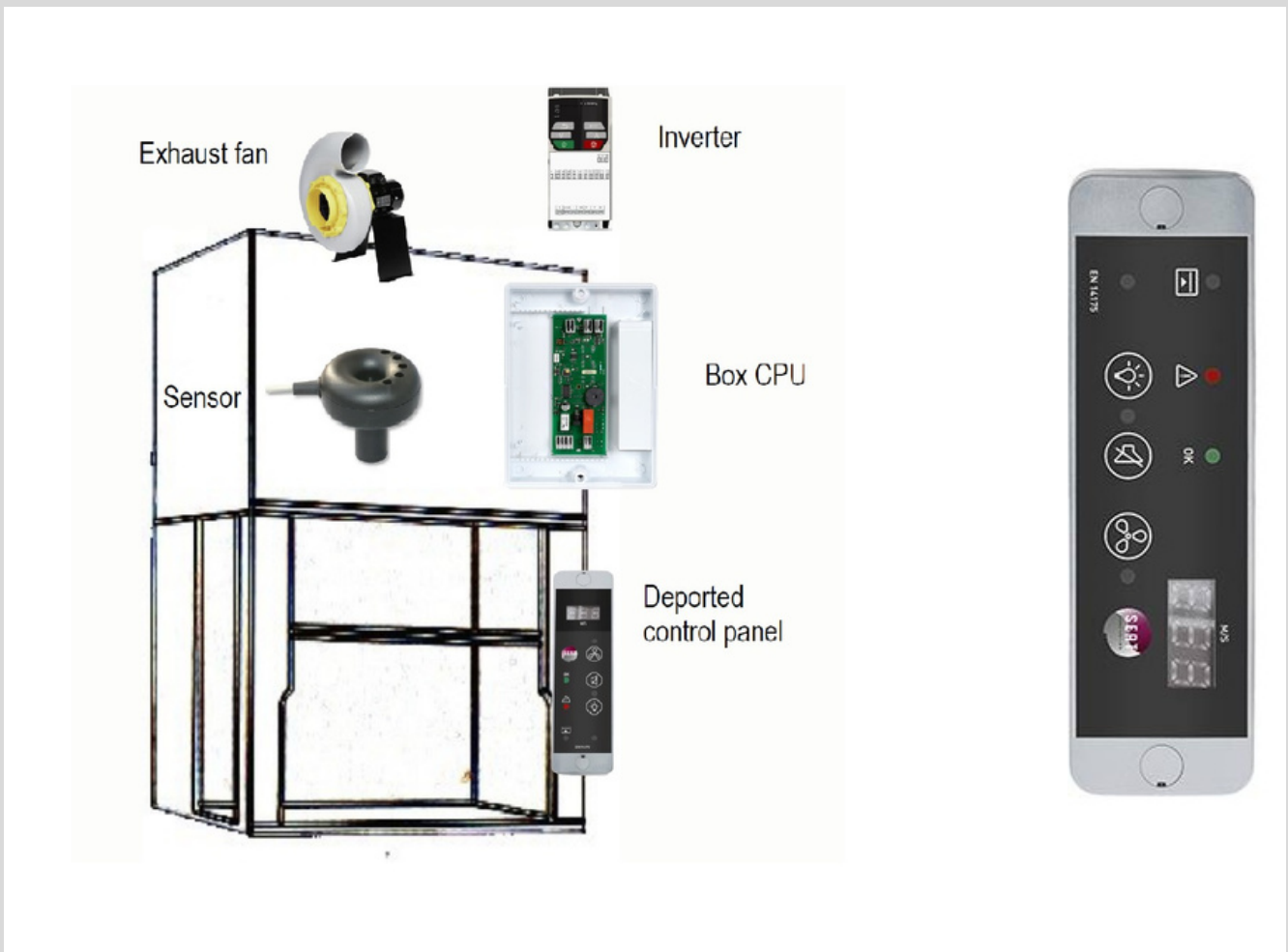

Equipped with variable airflow controller

The 0-10v output signal of the controller can be connected to a frequency inverter or motorized damper  
Automatically regulates airtightness.

Significant energy savings of more than 60% while ensuring the highest level of safety.

Prevents the fume hood user about a loss of face velocity or if the sash is raised above the safe working height.

Adapted to all laboratory applications

## OPTIONAL ACCESSORIES FOR FUME CUPBOARD

### BYPASS SYSTEM

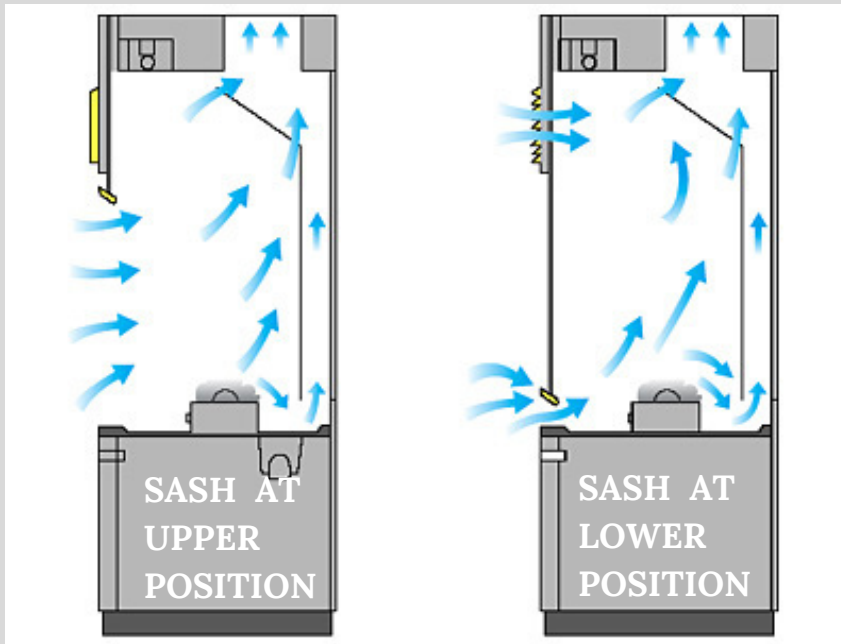

The bypass system allows air flow even while the sash is closed. This provides constant air volume regardless of sash position. The air bypass provides for an alternate route for air to enter the hood if the sash is closed.

Bypass openings are also used to combat the air velocity issues that can occur with conventional fume hoods.

### ATEX RATED ACCESSORIES



Fume hood with ATEX system integration, consisting of a set of explosion proof fittings and wiring materials.

All electrical components including socket outlets, LED lighting and wiring system are suitable for Zone 2 Hazardous atmospheres. But the main control panel has to be at Safe Area located within 20m of the fumecupboard with all associated Industrial standard wiring installation.

## OPTIONAL ACCESSORIES FOR FUME CUPBOARD

### AIRFLOW MONITOR PANEL



Audible alarm and led visual

Ventilation ON/OFF

Fume hood light ON/OFF

Prevents the fume hood user in case of air speed too low

Prevents the user if the sash is raised above the safe working height

Remote control panel with small sizes (4cm\*13cm)

### FIRE SUPPRESSION SYSTEMS



Pre-engineered fire suppression system with gas fire protection for fume cabinets using CO<sub>2</sub> extinguishing agent.

Fast and effective individual fume hood fire protection and fume cabinet fire suppression  
The automatic fire detection and automatic fire extinguishing system installs directly inside fume chamber and exhaust hood – closer to where a fire can start.

System use linear detection tubing which is installed throughout the risk area and connected to the cylinder valve.

A complete, ready-to-install automatic fire suppression system includes: cylinder, differential pressure valve, discharge tubing and nozzles, manual actuator, connectors and mounting brackets

Available in 5 Kg and 10 Kg sizes

## OPTIONAL ACCESSORIES FOR FUME CUPBOARD

### AUXILIARY AIR SUPPLY SYSTEMS



Auxiliary air supply units are intended for use when it is not feasible to introduce the required makeup air through the room ventilation systems.

An additional supply air plenum on the top, front portion of the hood supplies the required make-up air directly onto the face of fume hood via its own blower and ducting. Auxiliary air supply volume can be made equal to the Exhaust air - therefore there is no air required from the laboratory space.

Auxiliary air is being brought from outside area and it has been filtered thru a Sand louver and Blue fiber filters. The blower speed can be regulated with rotary speed regulator.

Diffusers are with volume and air direction adjustable louvers.

**This system is not recommended during extreme hot and humid ambient conditions.**

The advantage of an auxiliary air supply to fume hood is that up to 70% of the air required for the station can be pulled in and utilized from the outside. By using unconditioned, outside air, energy consumption is effectively minimized.

# FUME EXTRACTORS SUCTION ARMS

## FUME EXTRACTORS / SUCTION ARMS



### FUMEX - ME

The ideal extractor for laboratory environments  
The unique joint design of the Fumex ME results in a very low pressure drop, which produces many valuable benefits:



### MEX AA

Telescopic local extractor for atom absorption apparatus  
MEX AA is specially developed for the extraction of airborne pollutants at high temperatures generated from atom absorption apparatus.



### FUMEX - MF

MF Mobile filter for welding smoke and fine dust in temporary workplaces  
A flexible filter for use in temporary welding operations  
High cleaning efficiency  
Powerful extraction capacity



### MiniTEX

MiniTEX For workplaces requiring the market's lowest pressure drop  
Suitable in environments where the extractor can be incorporated in the same extraction system as other products with a low pressure drop such as fume cabinets or existing ventilation systems

## PICTURES



# EXPULSER

## PICTURES



## PICTURES





## OUR PARTNERS



### DISCLAIMER

The plans, images, specifications and other details given in this brochure are only indicative and the developer reserves the right to change any or all of these in the interest of the project or development. This document does not constitute an offer or any contract of any nature whatsoever. Any purchases/ legal agreement or document/s in any project shall be governed by the terms and conditions of the agreement entered into between the parties and no details mentioned in this document shall govern the transaction.



**BON FURNITURE INDUSTRIES LLC**

Mobile: +971 50 6703704, +971 52 6475053

Tel: +971 6 5569188

Email: sales@bonlabin.com

Address: P.O. Box 66902, Emirates Industrial City,

SHARJAH, UNITED ARAB EMIRATES



For More Details Scan

**Ethiopia**

More Tech

Mobile: +251 988899395

Email: sales@labethiopia.com

Address: More Tech, Addis Ababa,  
Ethiopia



**OMAN**

Lab Gulf

Mobile: +968 79204183

Email: naveen@labgulf.com

Address: P.O.Box: 178 P.C: 134, Al Watayya,  
Muscat, Oman SULTANATE OF OMAN



**Saudi Arabia**

Integrated Modern Scientific Supplies LLC,

Tel: +966 11 293 1199,

E-Mail: sultan@gulfbioanalytical.com

Address: PO Box: 285639, Riyadh-11323,  
Kingdom of Saudi Arabia



**Qatar**

Falkland Projects

Mobile: +974 3363 4872

Email: gm@falklandprojects.com

Address: PO Box: 82780 - Doha - State,  
Qatar



**KUWAIT**

Ideal Perfect Company

Mobile: +965 99703872

E-Mail: ipcokuwait@gmail.com

Address: Mubarak Commercial Complex, 2nd  
Floor, Office # 7, Jleeb Al Shuwaikh. Kuwait



**KENYA**

Nelliwa Builders Ltd

Mobile: +254727329627

Email: info@morayme.com

Address: P.O. Box. 68121, Code: 00200,  
Nairobi, Kenya



**Bahrain**

Mohammed Fakhroo & Bros. W.L.L

Mobile: +973 3990 1580

Email: sales@mylabfurniture.com

Address: P.O. Box 439,  
Manama, Bahrain

